

LED Directional

GU10 4.5 Watt and 7 Watt

Product information

This range provides a substantial energy saving and is direct replacement for the 35W and 50W halogen products by consuming only 4.5W and 7W of power.

Features

4.5W – 35W equivalent

Standard IEC size product with 200lm in beam.

7W – 70W equivalent

Large size product with 300lm in beam.

- 45,000 hours life
- Mercury free
- 200lm and 300lm
- 2700K and 3000K
- 25 degree and 35 degree beam angles

Application areas

Accent, display and general lighting applications in a wide variety of commercial, industrial and residential environments.



IEC standards

IEC60357: Tungsten halogen lamps (non-vehicle) – Performance specifications.

IEC62560: Self-ballasted LED lamp for general lighting services voltage 50~250V-safety specification.

EN60968: Self-Ballast lamps for general lighting services-Safety Requirements.

IEC62471: Photobiological safety of lamps and lamp systems.

EN55015: Limits and methods of measurement of radio disturbance characteristics of electrical lighting and similar equipment.

EN61547: Equipment for general lighting purposed EMC immunity requirements.

EN61000-3-2: Limits for harmonic current emissions.

EN61000-3-3: Limitation of voltage fluctuations and flicker in low voltage supply systems for equipment with rated current $\leq 16A$.

IEC60630: Maximum lamp outlines for incandescent lamps.

C78.21-2003: American National Standard for Electric Lamps-PAR and R shapes.



LED4.5/GU10/827/220-240V/FL – 25° nominal beam angle

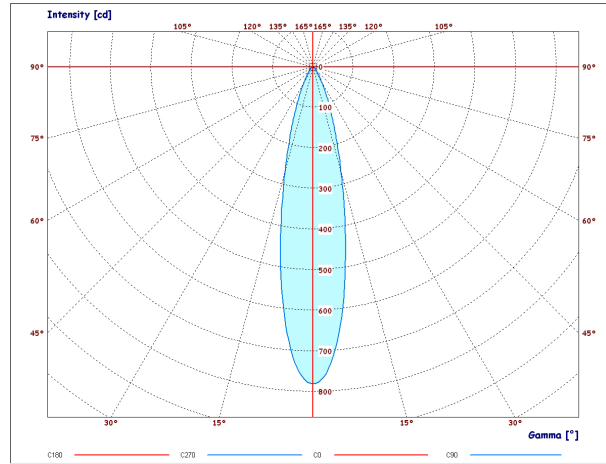
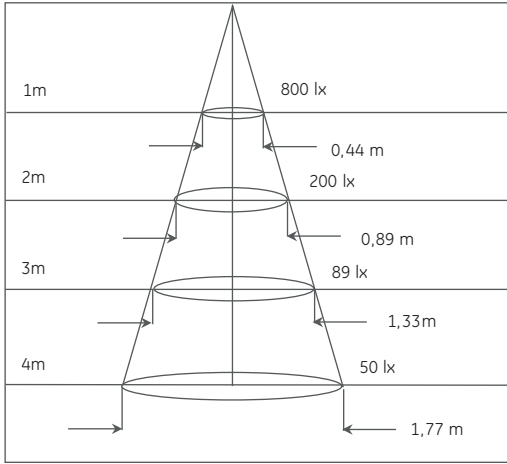

LED4.5/GU10/827/220-240V/WFL – 35° nominal beam angle

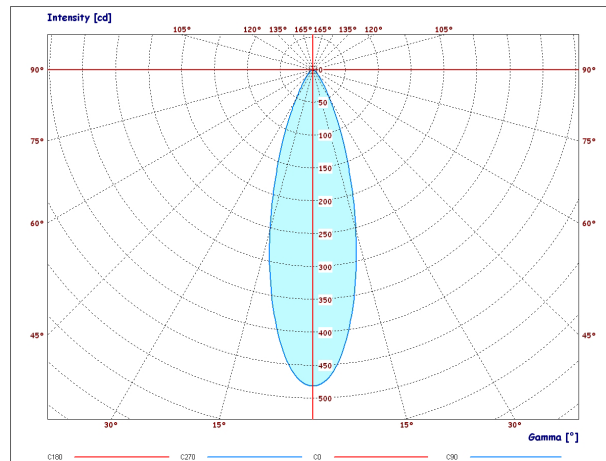
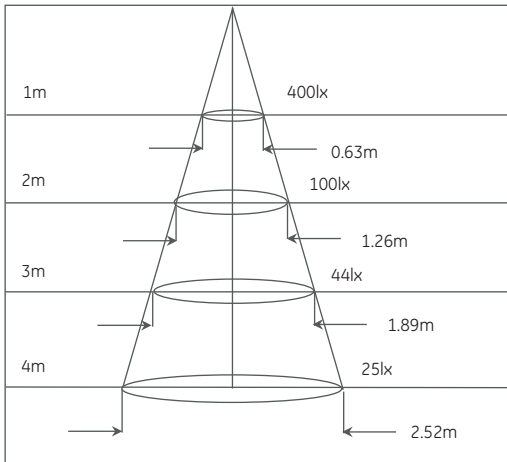

LED4.5/GU10/830/220-240V/FL – 25° nominal beam angle

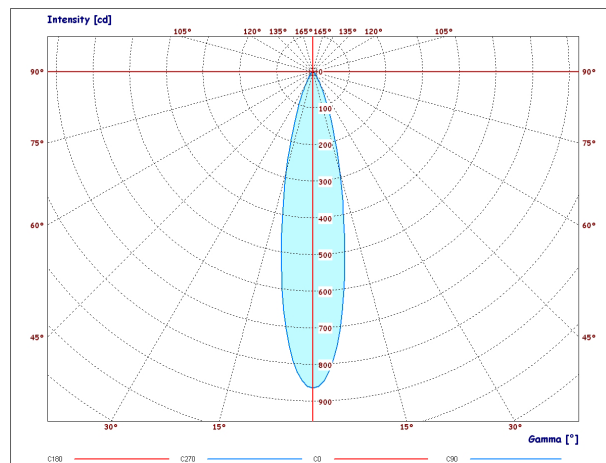
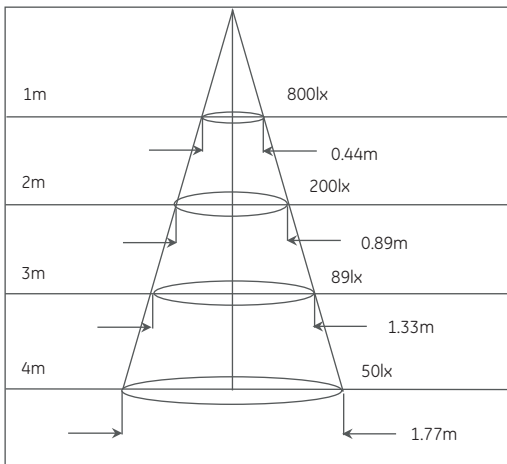

LED4.5/GU10/830/220-240V/WFL – 35° nominal beam angle

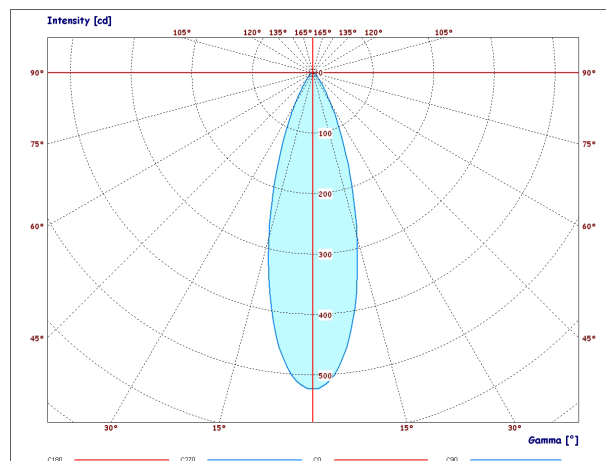
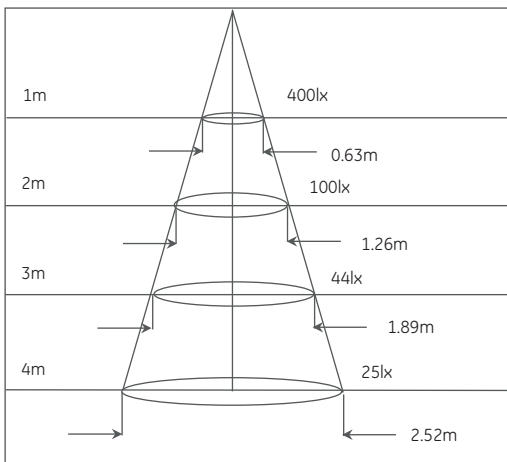

LED7/GU10/827/220-240V/FL – 25° nominal beam angle

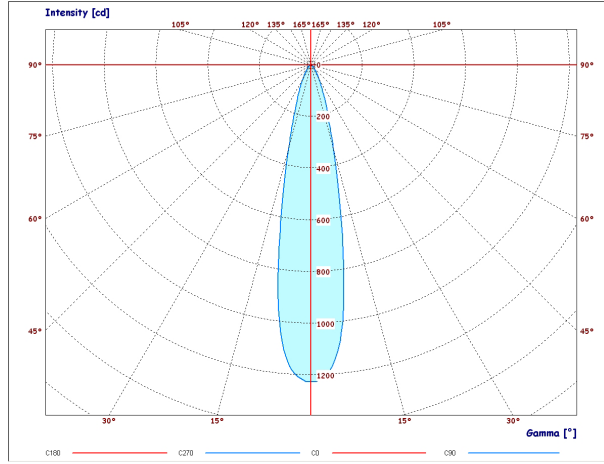
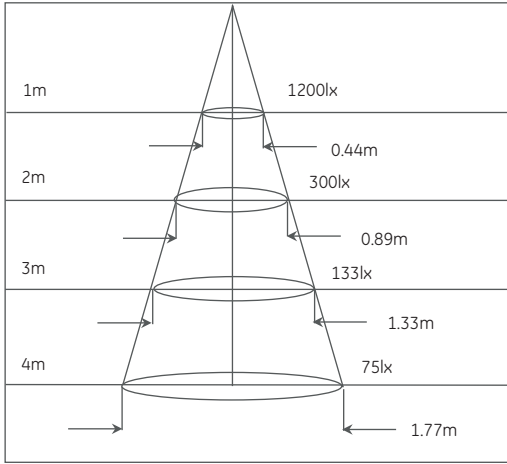

LED7/GU10/827/220-240V/WFL – 35° nominal beam angle

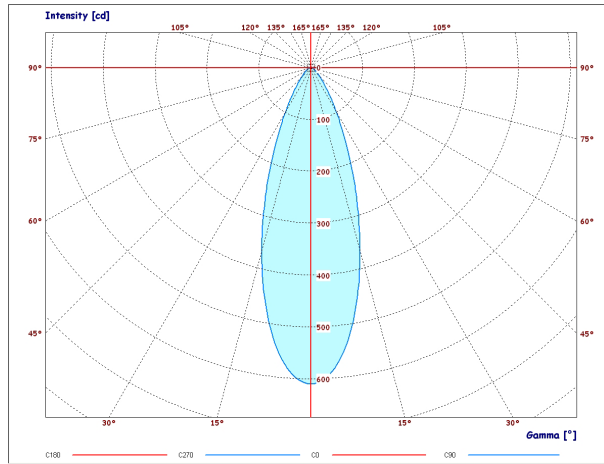
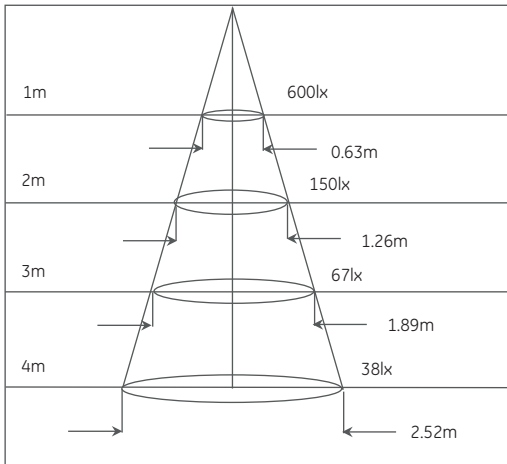

LED7/GU10/830/220-240V/FL – 25° nominal beam angle

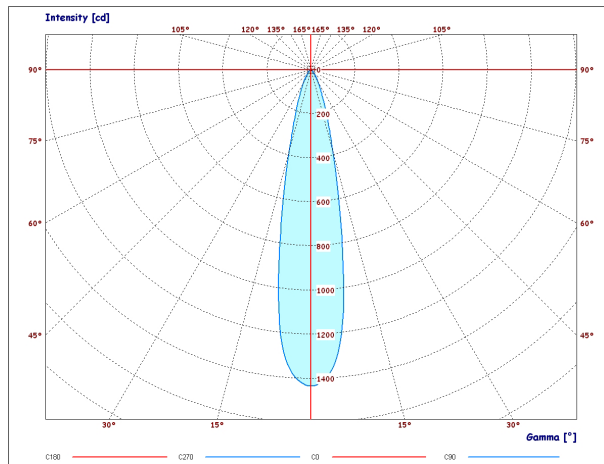
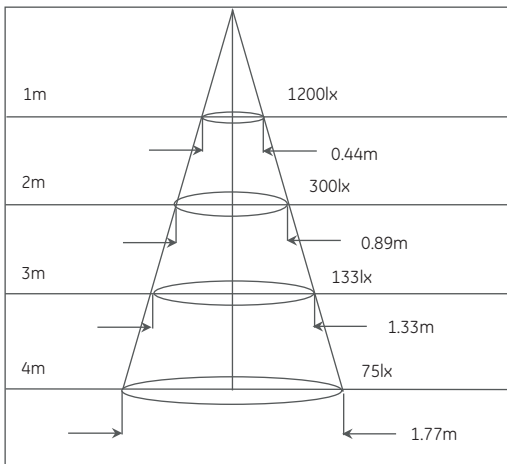

LED7/GU10/830/220-240V/WFL – 35° nominal beam angle

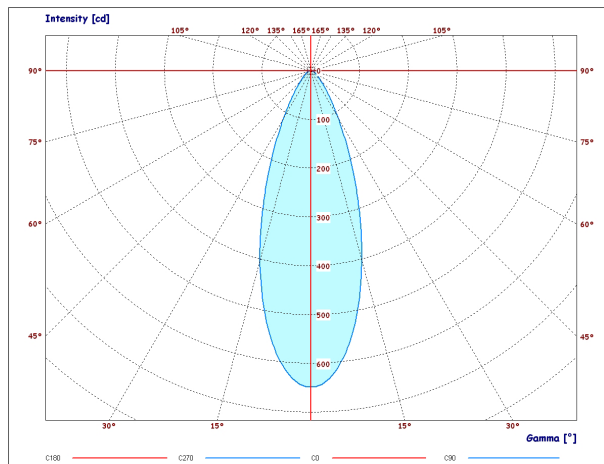
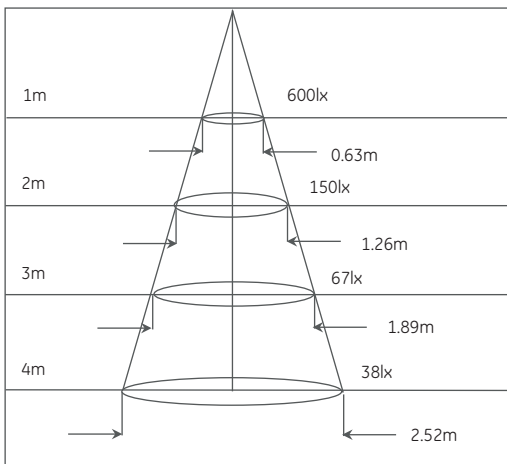

Basic data

4W and 7W GU10 LED lamps have the following common feature:

- "A" Class Energy
- 220-240V
- Colour rendering index: 80+
- Efficiency >40lm/W
- Operating temperature: $\geq -20^{\circ}\text{C}$ to $\leq 40^{\circ}\text{C}$

Product description	Watts	Base	CCT [K]	Beam Angle	CBCP	Life hours L70	Life hours B50	Lumen	Power Factor	Unit/Outer	Pack Type	Halogen Watt Reference
79358	LED4.5/GU10/827/220-240V/FL/BX	GU10	2700	25	800	25000	45000	200	0.5	1/8	TRBX	35
79359	LED4.5/GU10/827/220-240V/WFL/BX	GU10	2700	35	400	25000	45000	200	0.5	1/8	TRBX	35
79360	LED4.5/GU10/830/220-240V/FL/BX	GU10	3000	25	800	25000	45000	200	0.5	1/8	TRBX	35
79361	LED4.5/GU10/830/220-240V/WFL/BX	GU10	3000	35	400	25000	45000	200	0.5	1/8	TRBX	35
79362	LED7/GU10/827/220-240V/FL/BX	GU10	2700	25	1200	25000	45000	300	0.7	1/8	TRBX	50
79363	LED7/GU10/827/220-240V/WFL/BX	GU10	2700	35	600	25000	45000	300	0.7	1/8	TRBX	50
79364	LED7/GU10/830/220-240V/FL/BX	GU10	3000	25	1200	25000	45000	300	0.7	1/8	TRBX	50
79365	LED7/GU10/830/220-240V/WFL/BX	GU10	3000	35	600	25000	45000	300	0.7	1/8	TRBX	50

Dimensions

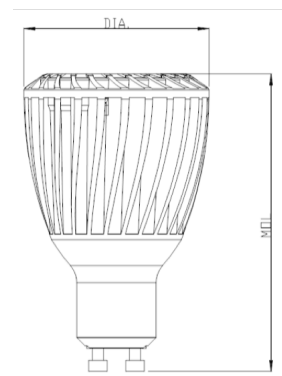
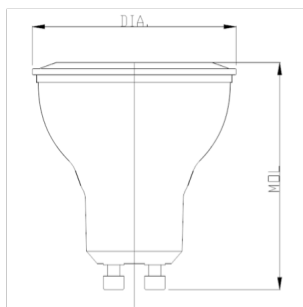

IEC-size GU10		
Wattage [W]	MOL [mm]	DIA [mm]
4.5	56.5	50.2

Large-size GU10		
Wattage [W]	MOL [mm]	DIA [mm]
7	77.6	50.2

MOL: maximum overall length
Diameter: maximum lamp diameter
Luminaire must be able to support 250g

Lumen maintenance at rated life

>90% reliability at 25,000 hours

Operation and maintenance

- Store and use the lamps the same way as traditional incandescent lamps.
- Fuse is not required in circuit.
- Observe wattage limitations of your fixture.
- Lamps should be kept free from contamination.
- Good condition of the lampholder contacts is important to ensure proper operation of lamp.
- Ensure lamp is cool before removing.
- Do not use the lamp if the outer jacket is broken, even if the burner still operates. There is a risk of electric shock.
- Switch off mains supply before installing/removing lamp.
- LED GU10 lamps are not dimmable.